



KENNEDY VALVE

UL-FM 200 PSI RESILIENT WEDGE GATE VALVE, SERIES 7000'S, KS-RW, KS-FW, MODEL 2638

2 1/2" - 24"

Overview

Kennedy Valve Series 7000 KS-RW and KS-FW gate valves are resilient EPDM encapsulated ductile iron wedge gate valves that are used in fire protection systems and water service applications. They offer bubble tight, bi-directional, on-off flow control. Series 7000s are compliant with AWWA C515 4" to 12" and UL Listed and FM Approved as KS-RW and AWWA C509 compliant 2 1/2" to 3" and UL Listed and FM Approved as KS-FW. Additionally, they are UL Listed and FM Approved 14" to 24" as Model 2638. All are constructed of durable ductile iron formulated to ASTM 70-50-05.

The Series 7000 family utilize triple EPDM o-ring stem seals and o-rings at the bonnet to body connection offering best in class performance and serviceability. The OS&Y utilizes a single o-ring and packing. The two uppermost stem o-rings of the NRS valve as well as OS&Y packing can be replaced while the valve is in service (consult our O&M for details).

Several end conditions are available including: ANSI CL 125 flange, IPS groove by groove, flanged by IPS grooved,

mechanical joint, push on for both C900 PVC and ductile iron pipe, as well as flange by MJ.

Series 7000s are coated with a high-performance heat curable, thermosetting fusion bonded epoxy system. This Kennedy Valve Powder coating system is FDA Title 21 section 175.300 accepted and is AWWA C550 compliant. Optionally 14" to 24" OS&Y's and PIV's are available with two part epoxy enabling easy repairs and top coating.

All OS&Y valves are manufactured with pre-notched stems to accommodate tamper switches by others.

Valves can be manufactured to be compliant with Buy American, Buy America, and BABA requirements.

All Kennedy KS-RW's and KS-FW's are manufactured and assembled at Kennedy Valve in Elmira, NY.

USC approved for cross connect

Manufacturing Standards - ISO 9001, ISO 14001, ISO 45001.

All OS&Y's come standard with fully adjustable packing to accommodate changing conditions and to maintain valve performance. Because of this feature it is expected that some adjustment of the packing gland may be required upon commissioning. Please see latest published O&M for procedure.



The KVOS2 tamper switch is an available option on 12" and smaller Kennedy OS&Y's, see page 7.



Certified to NSF/ANSI/CAN 61 & 372



* - Certified lead free by Alden Laboratories to NSF/ANSI/CAN 61 & 372 standards.

Technical Data

Available Sizes: 2 1/2" to 24"

UL-FM Listed and Approved Pressure: 200psi, 250psi 14-16"

FLANGES

Stocked: ANSI B16.1 Flat Face Flange, CL 125, CL 150 Drilling

Optional: CL 125 with PN16 Drilling (12" and down)

GROOVED

Stocked: Standard IPS Grooves per ANSI/AWWA C606

FASTENERS

Stocked NRS: 304 Stainless Steel

Stocked OS&Y: Plated Steel

Optional: 316 Stainless Steel, OS&Y also available in 304 Stainless Steel

STEM

NON-RISING GATE VALVE

Stocked: ASTM B584 High Strength Manganese Bronze or ASTM B763 NDZ

Optional: ASTM A276 Type 304ss, Type 316ss

OS&Y GATE VALVE (2 1/2" to 12")

Stocked: ASTM A276 Type 304ss
Optional: ASTM A276 Type 316ss, ASTM B371 Eco Brass,

OS&Y GATE VALVE (14" - 24")

Stocked: ASTM A276 Type 304ss
Optional: ASTM A276 Type 316ss, ASTM B371 Eco Brass, ASTM B98 Silicon Bronze (Everdur)

BODY TAPPING

12" and down Kennedy ULFM NRS and OS&Y valves can be tapped up to 4 locations. Flanged end valves come stocked with a tap located in the "A" position with an optional tap in the "B" position. Flange by Groove and Grooved end valves are stocked with A,B,&F locations tapped, an additional tap in the "E" position is optional. See figure 3 on page 3 for locations on the valve body. All taps are NPT, 2 1/2" - 3" are 1/2", 4" - 12" are 3/4". Plugs are coated over during the Kennedy Powder Coating process. Plugs can be either silicon bronze or low carbon steel. The plugs are easily removed by utilizing 4-point sockets.

Components

NRS WITH POST PLATE

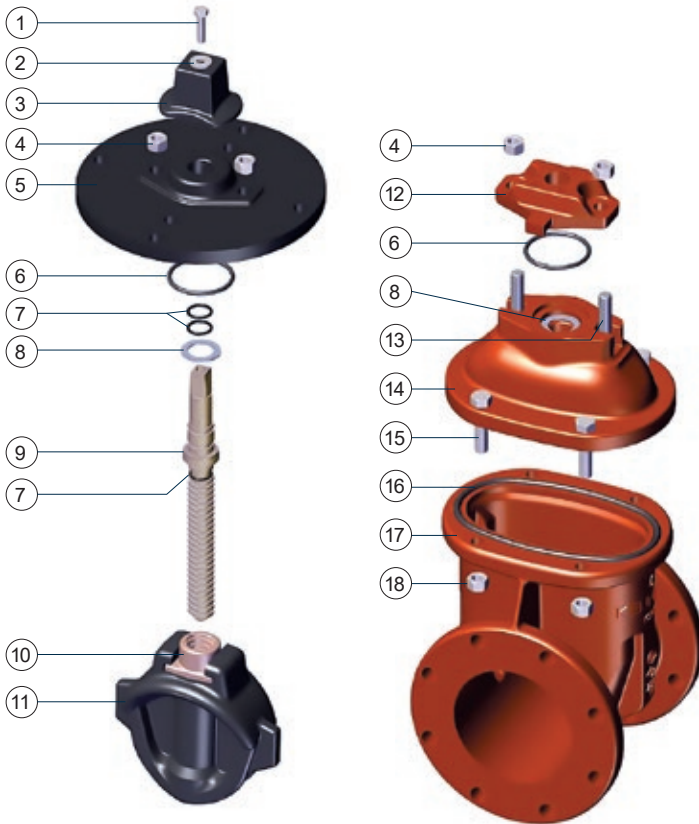

OS&Y



Tapped hole in OS&Y yoke shown for illustration; only available on 12" and down valves when factory installed KVOS is added.

Figure 1

Dimensions

No.	NRS	OS&Y	Description	Material
1	•		Op-Nut Bolt	Stainless Steel
2	•		Op-Nut Washer	Stainless Steel
3	•		Op-Nut	Ductile Iron
4	•	•	Post Plate/Stuffing Box Nut	Stainless Steel
5	•		Post Plate	Cast Iron
6	•		Post Plate/Stuffing Box O-Ring	Rubber
7	•	•	Stem O-Rings	Rubber
8	•		Thrust Teflon Washer	Plastic
9	•		Stem	Silicon Bronze
10	•		Stem Nut	Bronze
11	•	•	Resilient Wedge	EPDM Encapsulated Ductile Iron
12	•		Stuffing Box	Ductile Iron
13	•		Post Plate/Stuffing Box Plate Bolt	Ductile Iron/Stainless
14	•	•	Cover	Ductile Iron
15	•	•	Bonnet/Cover/Body Bolt	Plated Steel (OS&Y) Stainless Steel (NRS)
16	•	•	Bonnet/Cover/Body O-Ring	Rubber

No.	NRS	OS&Y	Description	Material
17	•	•	Body	Ductile Iron
18	•	•	Bonnet/Cover/Body Nut	Plated Steel (OS&Y) Stainless Steel (NRS)
19		•	Packing Gland	Ductile Iron
20		•	Packing	Garlock Style 18
21		•	Handwheel Nut	Bronze
22		•	Handwheel	Cast Iron
23		•	Bonnet/Cover	Ductile Iron
24		•	Yoke Washer	Plastic
25		•	Yoke Nut	Bronze
26		•	Packing Bolt	Plated Steel
27		•	Hex Nut	Brass
28		•	Stem	Pre-Notch Stainless Steel
29		•	Stem O-Ring	Rubber
30		•	Stem Pin	Stainless Steel
31		•	Stem Nut	Bronze
32		•	Handwheel Yoke Washer	Brass

Components

NRS WITH POST PLATE

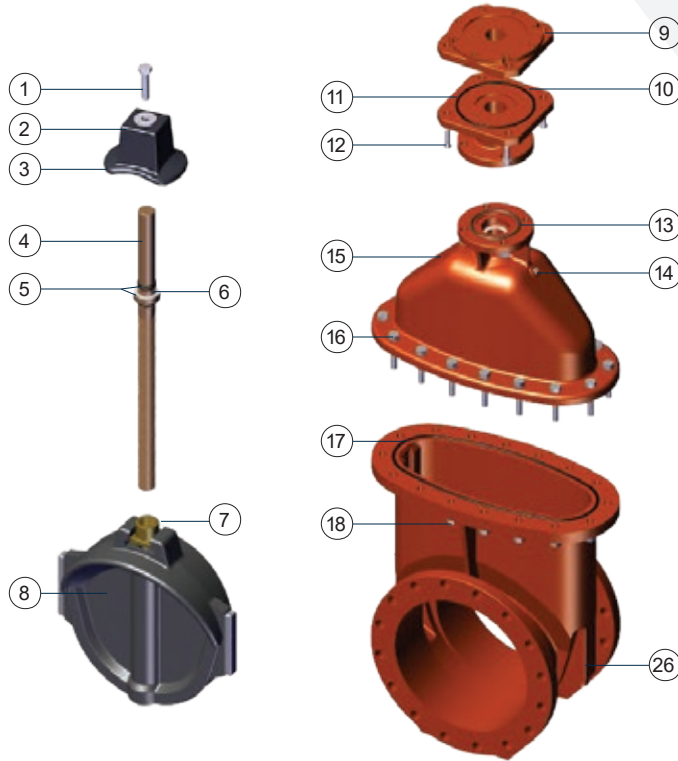

OS&Y

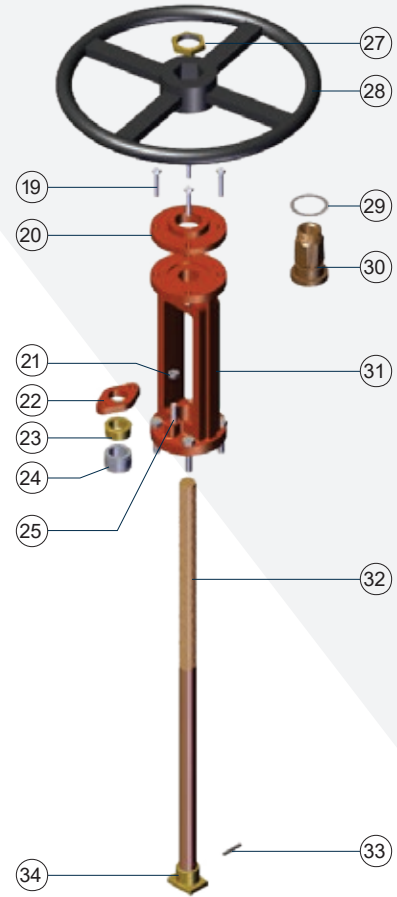

Figure 2: See page 14 for info on the CleanTrack™ system installed on 24" valves.

Dimensions

No.	NRS	OS&Y	Description	Material
1	•		Op-Nut Bolt	Stainless Steel
2	•		Op-Nut Washer	Stainless Steel
3	•		Op-Nut	Ductile Iron
4	•		NRS Stem	Manganese Bronze
5	•		NRS Stem O-Ring	Rubber
6	•		Thrust Washer	Plastic
7	•		NRS Stem Nut	Bronze
8	•	•	Resilient Wedge	EPDM Encapsulated Ductile Iron
9	•		Post Plate	Ductile Iron
10	•		Stand/Plate O-Ring	Rubber
11	•		NRS Extension Stand	Ductile Iron
12	•		Stand/Plate Bolt	Stainless Steel
13	•		Stand/Cover O-Ring	Rubber
14	•	•	Pipe Plug	Stainless Steel
15	•	•	Cover	Ductile Iron
16	•	•	Cover/Body Hex Bolts	Stainless Steel
17	•	•	Cover/Body O-Ring	Rubber
18	•	•	Bonnet/Cover/Body Nut	Plated Steel (OS&Y) Stainless Steel (NRS)

No.	NRS	OS&Y	Description	Material
19		•	Yoke/Plate Hex Nut	Plated Steel
20		•	Retainer Plate	Cast Iron
21		•	Packing Gland Hex Nut	Plated Steel
22		•	Follower Plate	Ductile Iron
23		•	Follower Gland	Bronze
24		•	Packing	Garlock Style 18
25		•	Follower Bolt	Plated Steel
26		•	Body	Ductile Iron
27		•	Wheel Nut	Bronze
28		•	Hand Wheel	Cast Iron
29		•	Yoke Washer	Plastic
30		•	Yoke Nut	Bronze
31		•	Yoke	Ductile Iron
32		•	Stem	Silicon Bronze
33		•	Stem Pin	Stainless Steel
34		•	OS&Y Stem Nut	Bronze

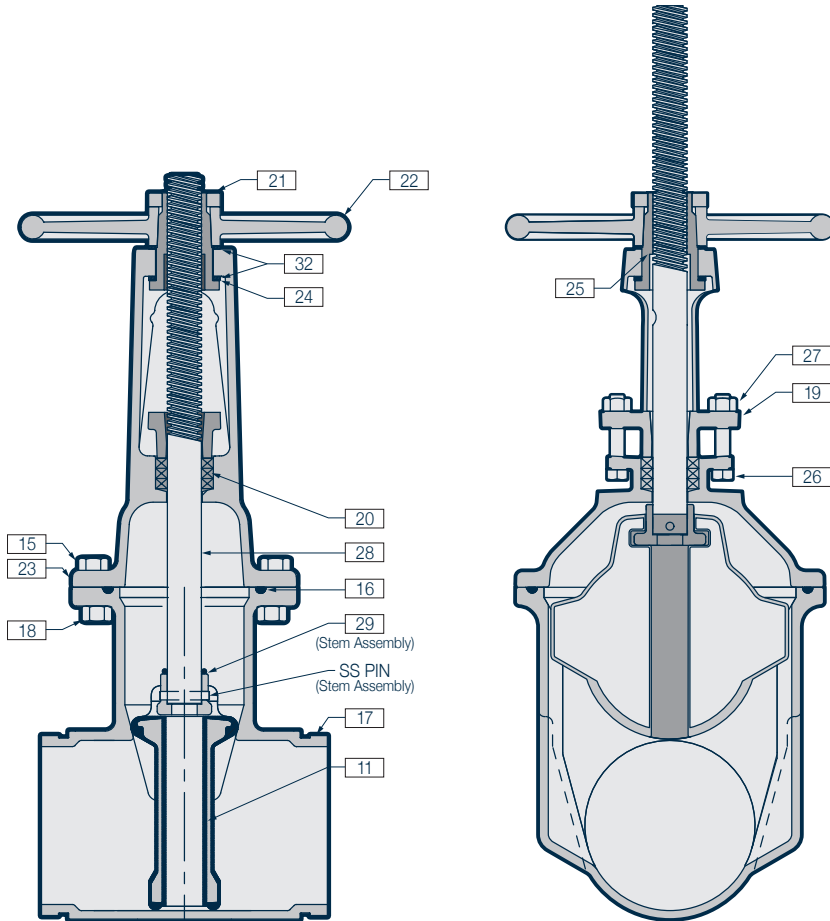

Figure 4

All standard OS&Y valves be provided with smooth stems (no switch activation details)

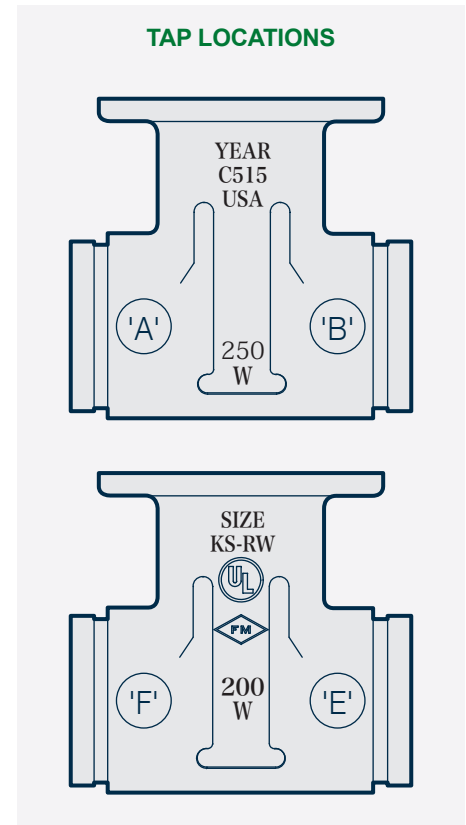

Figure 5

* - UL FM 14/16" body will indicate 250 PSI

Bill of Materials

Item	Description	No Req'd	Material
21	Handwheel Nut	1	Bronze
22	Handwheel	1	Cast Iron
32	Thrust Washer (upper/lower)	1 ea	Bronze (2"/2.5" Delrin/Celcon)
24	Anti-Friction Bearing	1	Nylatron Sizes 3" - 12"
15/18	Hex Head Bolts / Hex Nuts	varies	Plated Steel
23	Bonnet/Cover	1	Ductile Iron
20	Packing	1	Square Braided Non-Asbestos
28	Stem	1	304 Stainless Steel
16	O-Ring	1	Buna-N
29	O-Ring (Stem Assembly)	1	Buna-N
17	Body	1	Ductile Iron
11	Resilient Wedge	1	DI, EPDM Encapsulated Wedge
25	Yoke Nut	1	Bronze
27	Hex Nuts	2	Brass
19	Gland	1	Ductile Iron
26	Square Head Bolts	2	Plated Steel

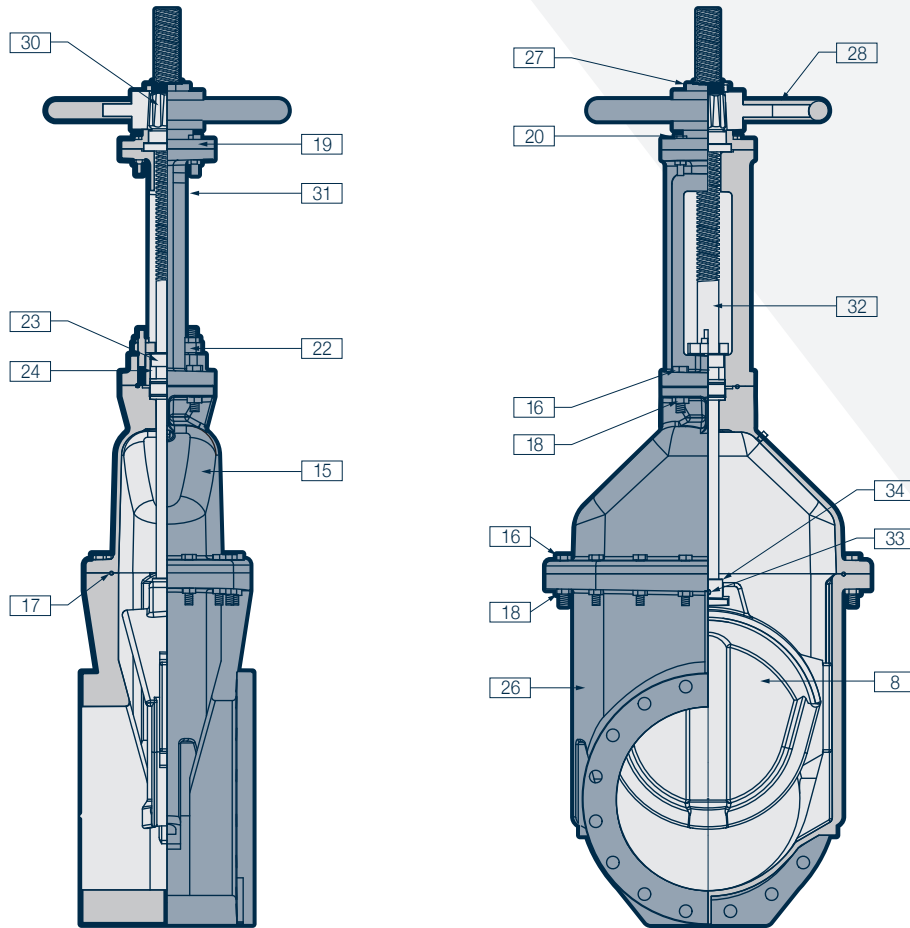

Figure 3: See page 14 for info on the CleanTrack™ system installed on 24" valves.

Bill of Materials

Item	Description	No Req'd	Material
27	Handwheel Nut	1	Bronze
28	Handwheel	1	Cast Iron
16/18	Hex Head Bolts/Hex Nuts	varies	Plated Steel
15	Bonnet/Cover	1	Ductile Iron
24	Packing	1	Garlock Style 18
32	Stem	1	Silicon Bronze
17	O-Ring	1	Buna-N
26	Body	1	Ductile Iron
8	Resilient Wedge	1	DI, EPDM Encapsulated Wedge
30	Yoke Nut	1	Bronze
22	Follower Plate	1	Ductile Iron
19	Yoke/Plate Hex Bolt	4	Plated Steel
34	Stem Nut	1	Bronze
31	Yoke	1	Cast Iron
20	Retainer Plate	1	Cast Iron
33	Stem Pin	1	Stainless Steel
23	Follower Gland	1	Bronze

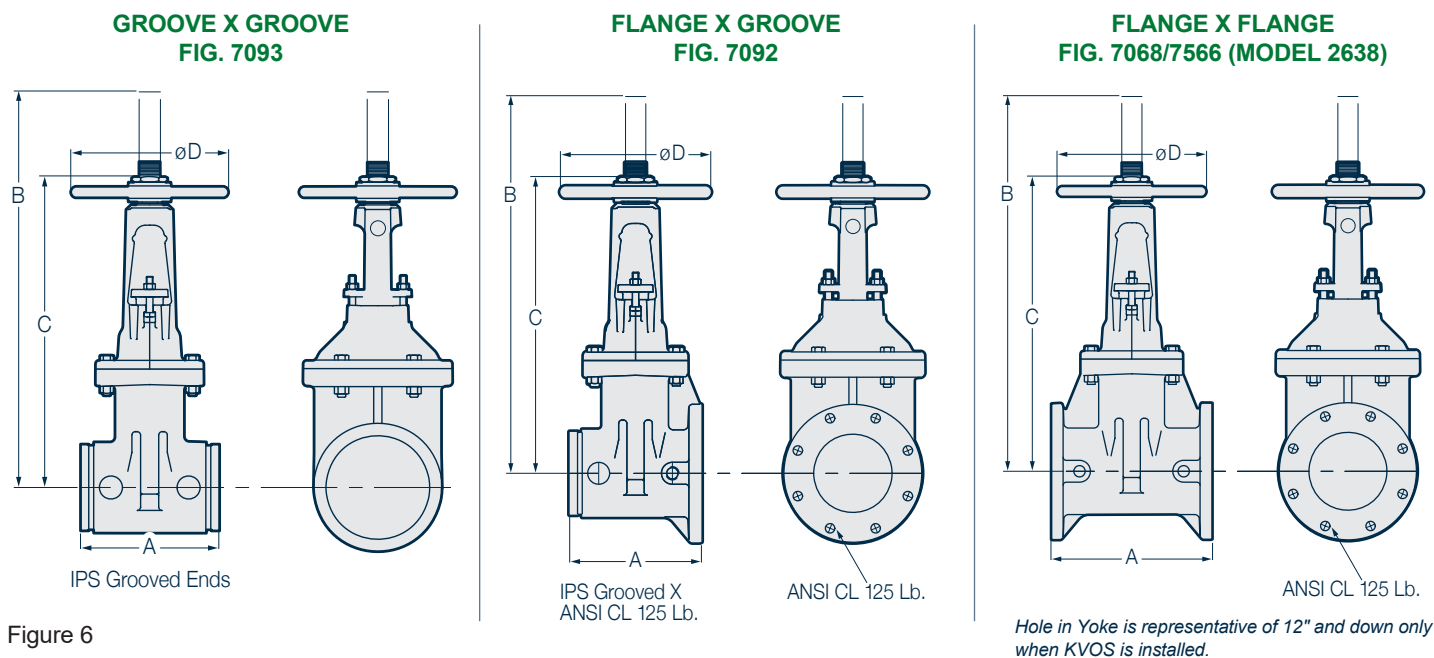

Figure 6

DIMENSIONS, WEIGHT, AND OPERATIONAL DATA – FIG. 7093, FIG. 7092, FIG. 7068 (12" and down only), FIG. 7566 (14"–24" only)

Size	Nominal Dimensions				No. of Bolts and Bolt Size per Flange	Turns to Operate	Weights in Pounds			Cv Full Open
	A	B	C	ØD			G x G	G x F	F x F	
2½"	7½"	16¾"	13⅞"	6½"	4 - 5/8"	8	37	40	52	500
3"	8"	18⅞"	15⅝"	10"	4 - 5/8"	10	48	57	67	800
4"	9"	22¾"	18¼"	10"	8 - 5/8"	13½	74	77	92	1500
6"	10½"	30⅞"	23¾"	12"	8 - 3/4"	19½	103	115	141	3600
8"	11½"	37¾"	29¼"	14"	8 - 3/4"	25½	139	171	213	6700
10"	13"	45¾"	35⅝"	18"	12 - 7/8"	31½	294	N/A	369	10,500
12"	14"	53⅞"	40⅝"	18"	12 - 7/8"	37¾	326	N/A	479	15,000
14"†	15"	78⅞"	60¾"	18"	12 - 1"	52	N/A	N/A	670	20,800
16"†	16"	77½"	60¾"	18"	16 - 1"	52	N/A	N/A	735	27,200
18"	17"	92⅞"	83¾"	24"	16 - 1¼"	64	N/A	N/A	1100	34,400
20"	18"	94⅞"	84⅞"	24"	20 - 1¼"	64	N/A	N/A	1325	42,400
24"	20"	110⅞"	97⅞"	24"	20 - 1⅝"	76	N/A	N/A	1900	61,100

†14" and 16" valves are UL Listed and FM approved to 250 psi.

Resilient Seated Gate Valves w/KVOS (Factory Installed Tamper)

KSRW OS&Y – FLANGED, FLANGED X GROOVE, GROOVE & ENDS GENERAL INFORMATION

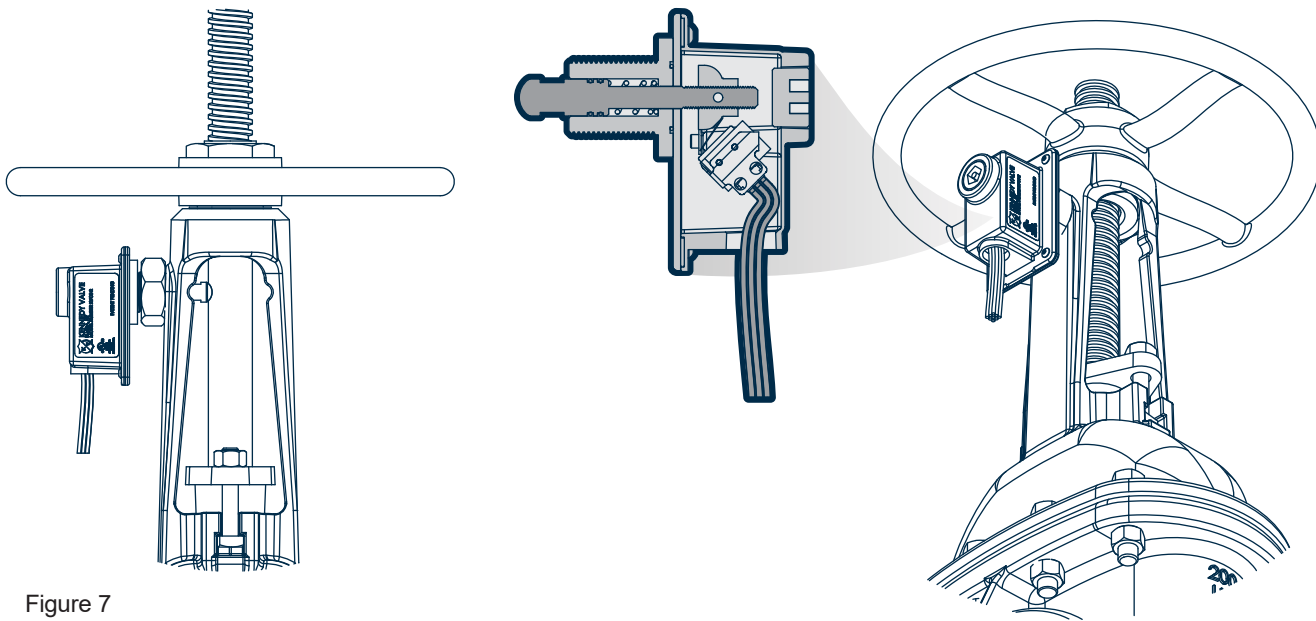

Figure 7



KVOS-2 FOR 2½"-12" OS&Y VALVES

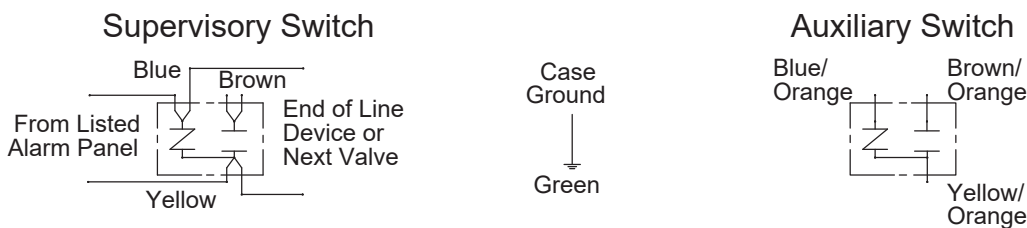

Figure 8

Rated: 120 VAC, 28 VDC, .25 A

WIRING NOTES: Connection to power limited circuitry is required. Auxiliary switch is for supplemental use only, and shall not be used for fire alarm signaling applications.

Switches are checked at factory, check continuity with valve fully open, switches activate within two turns from open.

CAUTION: PRIOR TO INSTALLATION OF SUPERVISORY SWITCHES IN FIRE PROTECTION SYSTEMS REFER TO THE FOLLOWING STANDARDS:

NFPA 13: STANDARD FOR THE INSTALLATION OF SPRINKLER SYSTEMS

NFPA 25: INSPECTION, TESTING, MAINTENANCE OF WATER BASED FIRE PROTECTION SYSTEMS

NFPA 70: NATIONAL ELECTRICAL CODE

NFPA 72: NATIONAL FIRE ALARM CODE

CSA C22.1 NO.1 CANADIAN ELECTRICAL CODE, PART 1, SAFETY STANDARD FOR ELECTRICAL INSTALLATIONS SECTION 32

CAN/ULC-S524, STANDARD FOR INSTALLATION OF FIRE ALARM SYSTEMS

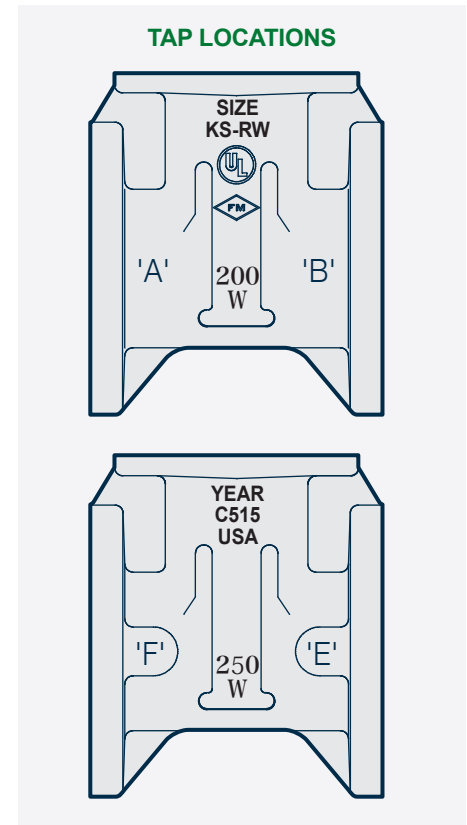
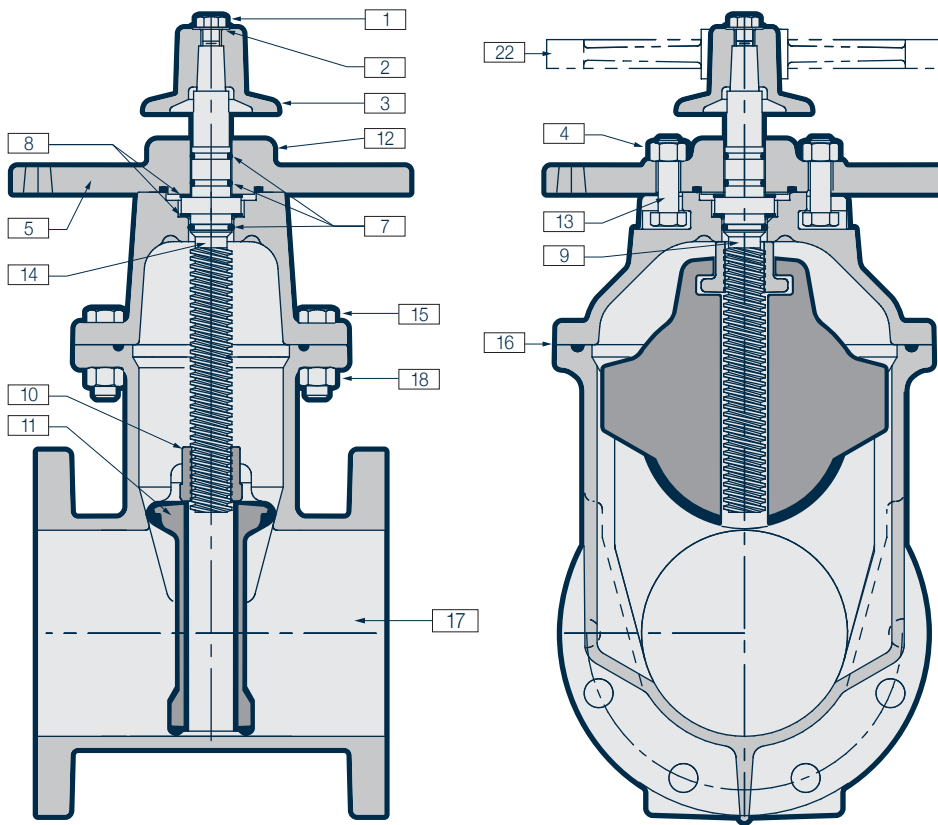

Figure 9

Figure 10

Bill of Materials

Item	Description	No Req'd	Material
1	Hex Head Bolt	1	Stainless Steel
2	Flat Washer	1	Steel, Plated
3	Operating Nut	1	Cast Iron
12	Stuffing Box	1	Ductile Iron
8	Thrust Washer	1	2" & 2.5" Delrin
		2	3" - 12" Delrin
5	Post Adaptor Plate (Optional)	1	Cast Iron (4 – ¾" holes on a 10½" diameter B.C.)
14	Bonnet/cover	1	Ductile Iron
10	Stem Nut	1	Bronze
11	EPDM Encapsulated Wedge	1	Ductile Iron
12	Stuffing Box	1	Ductile Iron
7	O-ring (Stem)	3	Buna-N
15	Hex. Head Bolts	Varies	Stainless Steel
18	Hex. Nuts	Varies	Stainless Steel
17	Body	1	Ductile Iron
22	Handwheel (Optional)	1	Cast Iron
4	Hex. Nuts	2	Stainless Steel
13	Stuffing Box Bolts	2	Stainless Steel
9	Stem	1	Bronze
16	O-ring (Cover)	1	Buna-N

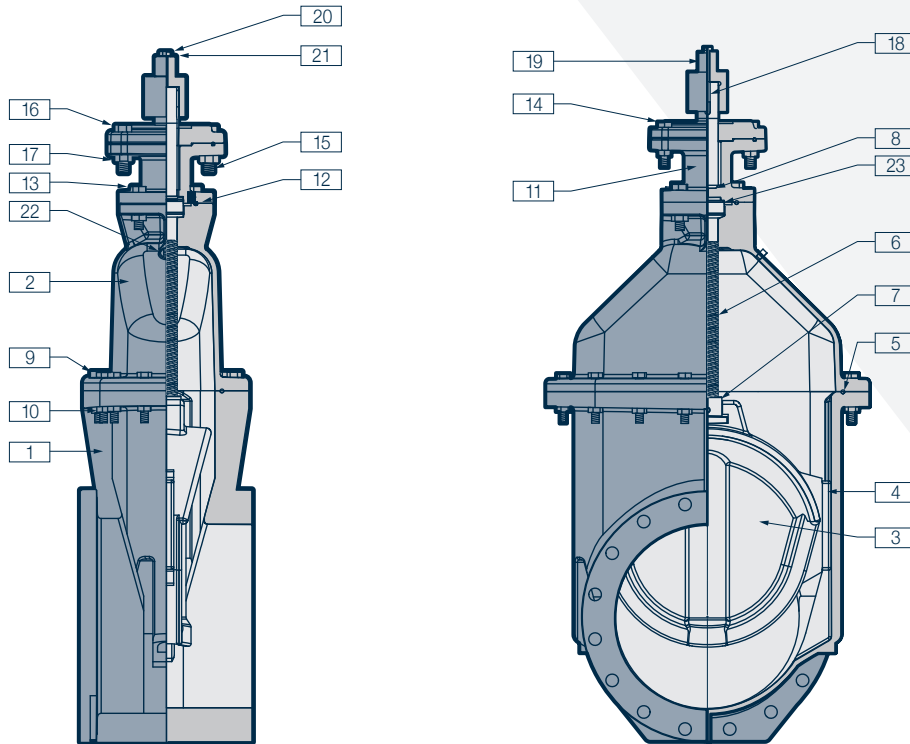

Figure 11: See page 14 for info on the CleanTrack™ system installed on 24" valves.

Bill of Materials

Item	Description	No Req'd	Material
1	Body	1	Ductile Iron
2	Cover	1	Ductile Iron
3	EDPM Encapsulated Wedge	1	EPDM Rubber and Ductile Iron
4	Wedge Cap	1	Delrin
5	O-Ring	1	EPDM Rubber and Ductile Iron Disc
6	Stem	1	Manganese Bronze
7	Stem Nut	1	Bronze
8	O-Ring	1	EPDM
9	Hex Bolt	Varies	Stainless Steel
10	Hex Nut	Varies	Stainless Steel
11	Extension (Stand)	1	Ductile Iron
12	O-Ring	1	EPDM
13	Hex Bolt	2	Stainless Steel
14	Indicator Adaptor Plate	1	Ductile Iron
15	O-Ring	1	EPDM
16	Hex Bolt	4	Stainless Steel
17	Nex Nut	4	Stainless Steel
18	Key	1	Steel
19	Operating Nut	1	Gray or Ductile Iron
20	Bolt	1	Stainless Steel
21	Flat Washer	1	Steel Plated
22	Pipe Plug	1	Carbon or Stainless Steel
23	Thrust Washer	Varies	Delrin

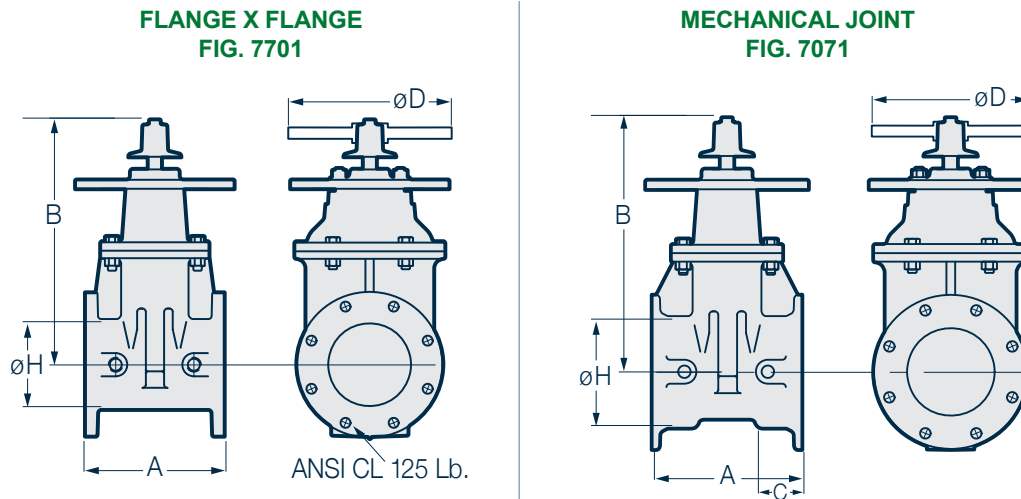

Figure 12 – All images are shown with Post Plate.

DIMENSIONS, WEIGHT, AND OPERATIONAL DATA - CLASS 125 FLANGE - FIG. 7701

Size	Nominal Dimensions			C (depth of socket)	No. of Bolts per Flange and Bolt Size	Weight with Plate	ØD Optional Handwheel Diameter	Turns to Operate	Post Plate Diameter	Cv Full Open
	A	ØH	B							
3"*	8"	3"	12 ³ / ₈ "	N.A.	4 - 5/8"	80	10"	10	12"	800
4"	9"	4 ¹ / ₄ "	14 ³ / ₄ "	N.A.	4 - 3/4"	102	10"	13	12"	1500
6"	10 ¹ / ₂ "	6 ¹ / ₄ "	19"	N.A.	6 - 3/4"	139	12"	19	12"	3600
8"	11 ¹ / ₂ "	8 ¹ / ₄ "	22 ¹ / ₂ "	N.A.	6 - 3/4"	208	14"	25	12"	6700
10"	13"	10 ¹ / ₄ "	26 ¹ / ₂ "	N.A.	8 - 3/4"	350	18"	31	12"	10500
12"	14"	12 ¹ / ₄ "	30"	N.A.	8 - 3/4"	445	18"	37	12"	15000
14" [†]	15"	14 ¹ / ₄ "	38 ³ / ₄ "	N.A.	12 - 1"	670	26"	52	12"	20800
16" [†]	16"	16 ¹ / ₄ "	37 ³ / ₄ "	N.A.	16 - 1"	720	26"	52	12"	27200
18"	17"	18 ¹ / ₄ "	57 ¹ / ₁₆ "	N.A.	16 - 1 ¹ / ₄ "	1100	26"	64	13 ¹ / ₄ "	34400
20"	18"	20 ¹ / ₄ "	56 ¹ / ₄ "	N.A.	20 - 1 ¹ / ₄ "	1325	26"	64	13 ¹ / ₄ "	42400
24"	20"	24 ¹ / ₄ "	60 ¹ / ₁₆ "	N.A.	20 - 1 ³ / ₈ "	1732	30"	76	13 ¹ / ₄ "	61100

DIMENSIONS, WEIGHT, AND OPERATIONAL DATA - MJ - FIG. FIG. 7071

Size	Nominal Dimensions			C (depth of socket)	No. of Bolts per Flange and Bolt Size	Weight with Plate	ØD Optional Handwheel Diameter	Turns to Operate	Post Plate Diameter	Cv Full Open
	A	ØH	B							
3"*	8 ¹ / ₂ "	3"	12 ³ / ₈ "	2 ¹ / ₂ "	4 - 5/8"	60	10"	10	12"	800
4"	9 ¹ / ₂ "	4 ¹ / ₄ "	14 ³ / ₄ "	2 ¹ / ₂ "	4 - 3/4"	90	10"	13 ¹ / ₂	12"	1500
6"	10 ¹ / ₂ "	6 ¹ / ₄ "	19"	2 ¹ / ₂ "	6 - 3/4"	128	12"	19 ¹ / ₂	12"	3600
8"	13 ¹ / ₈ "	8 ¹ / ₄ "	22 ¹ / ₂ "	2 ¹ / ₂ "	6 - 3/4"	189	14"	25 ¹ / ₂	12"	6700
10"	15 ¹ / ₂ "	10 ¹ / ₄ "	26 ¹ / ₂ "	2 ¹ / ₂ "	8 - 3/4"	301	18"	31 ¹ / ₂	12"	10500
12"	16"	12 ¹ / ₄ "	30"	2 ⁵ / ₈ "	8 - 3/4"	384	18"	37 ³ / ₄	12"	15000
14" [†]	17"	14 ¹ / ₄ "	38 ³ / ₄ "	3 ¹ / ₂ "	10 - 3/4"	670	26"	52	12"	20800
16" [†]	17"	16 ¹ / ₄ "	37 ³ / ₄ "	3 ¹ / ₂ "	12 - 3/4"	735	26"	52	12"	27200
18"	18 ³ / ₄ "	18 ¹ / ₄ "	57 ¹ / ₁₆ "	3 ¹ / ₂ "	12 - 7/8"	1100	26"	64	13 ¹ / ₄ "	34400
20"	18 ⁵ / ₁₆ "	20 ¹ / ₄ "	56 ¹ / ₄ "	3 ¹ / ₂ "	14 - 7/8"	1325	26"	64	13 ¹ / ₄ "	42400
24"	20"	24 ¹ / ₄ "	60 ¹ / ₁₆ "	3 ¹ / ₂ "	16 - 7/8"	1800	30"	76	13 ¹ / ₄ "	61100

*AWWA C509 compliant.

[†]14" and 16" valves are UL Listed and FM approved to 250 psi.

FLANGE X MECHANICAL JOINT
FIG. 7702

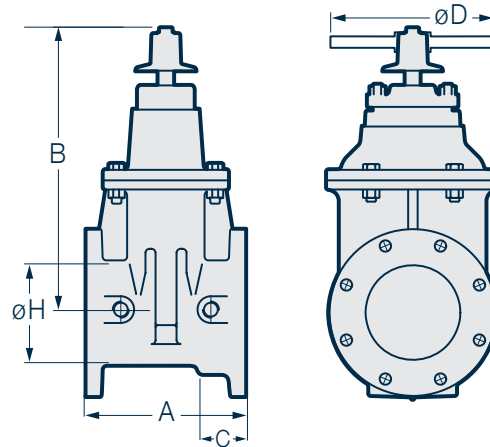

Figure 13

DIMENSIONS, WEIGHT, AND OPERATIONAL DATA - FLG X MJ - FIG. 7702

Size	Nominal Dimensions			C	No. of Bolts per Flange and Bolt Size	Weight with Plate	ØD Optional Handwheel Diameter	Turns to Operate	Post Plate Diameter	Cv Full Open
	A	ØH	B	(depth of socket)						
3" *	8¼"	4 ¹³ / ₁₆ "	12 ³ / ₈ "	2½"	4 - 5/8" 4 - 5/8"	N/A	10"	10	12"	800
4"	9¼"	4¼"	14¾"	2½"	8 - 5/8" 4 - 3/4"	96	10"	13½	12"	1500
6"	10½"	6¼"	19"	2½"	8 - 3/4" 6 - 3/4"	132	12"	19½	12"	3600
8"	12 ⁵ / ₁₆ "	8¼"	22½"	2½"	8 - 3/4" 6 - 3/4"	199	14"	25½	12"	6700
10"	14¼"	10¼"	26½"	2½"	12 - 7/8" 8 - 3/4"	325	18"	32	12"	10500
12"	15"	12¼"	30"	2 ⁵ / ₈ "	12 - 7/8" 8 - 3/4"	407	18"	37¾	12"	15000
14" [†]	17 ³ / ₈ "	14 ¼"	37 ¾"	3 ½"	12 - 1" 10 - ¾"	670	26"	52	12"	20800
16" [†]	16 ⁷ / ₈ "	16 ¼"	37 ¾"	3 ½"	16 - 1" 12 - ¾"	730	26"	52	12"	27200
18"	18 ¹³ / ₁₆ "	18 ¼"	57 ¹ / ₁₆ "	3 ½"	16 - 1 ¼" 12 - 7/8"	1100	26"	64	13¼"	34400
20"	18 ¹⁵ / ₃₂ "	20 ¼"	56 ¼"	3 ½"	20 - 1 ¼" 14 - 7/8"	1325	26"	64	13¼"	42400
24"	20 ½"	24 ¼"	60 ¹ / ₁₆ "	3 ½"	20 - 1 ¾" 16 - 7/8"	1765	30"	76	13¼"	61100

*AWWA C509 compliant.

[†]14" and 16" valves are UL Listed and FM approved to 250 psi.

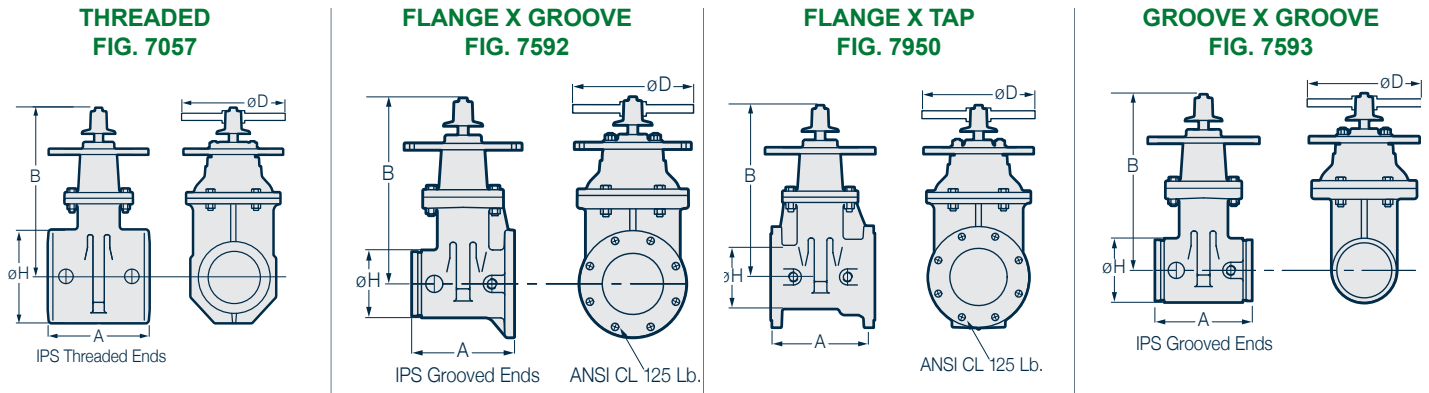

Figure 14

All NRS Post Plates are 12" diameter unless otherwise noted.

DIMENSIONS, WEIGHT, AND OPERATIONAL DATA - THREADED - FIG. 7057

Size	Nominal Dimensions			C (depth of socket)	No. of Bolts per Flange and Bolt Size	Weight with Plate	ØD Optional Handwheel Diameter	Turns to Operate	Post Plate Diameter	Cv Full Open
	A	ØH	B							
2½"	7		11⅝"		N/A	N/A	6"	8	12"	500
3"	7¼"		12⅜"		N/A	N/A	10"	10	12"	800

*AWWA C509 compliant

DIMENSIONAL WEIGHT AND OPERATIONAL DATA - FIG. 7592 / 7950 / 7593

NRS FLANGED END ANSI CL 125, GROOVED, GROOVED BY FLANGED, FLANGE X TAP (4" TO 12" ONLY)

Size	Nominal Dimensions			No. of Bolts per Flange and Bolt Size	Weight (with plate)	ØD Optional Handwheel Diameter	Turns to Operate	Post Plate Diameter	Cv Full Open
	A	ØH	B						
2½"	7½"	2½"	11⅝"	4 - ⅝"	65	7¼"	8	12"	500
3"	8"	3"	12⅜"	4 - ⅝"	79	10"	10	12"	800
4"	9"	4¼"	14¾"	8 - ⅝"	102	10"	13½	12"	1500
6"	10½"	6¼"	19"	8 - ¾"	139	12"	19½	12"	3600
8"	11½"	8¼"	22½"	8 - ¾"	208	14"	25½	12"	6700
10"	13"	10¼"	26½"	12 - ⅞"	340	18"	31½	12"	10500
12"	14"	12¼"	30"	12 - ⅞"	446	18"	37¾	12"	15000

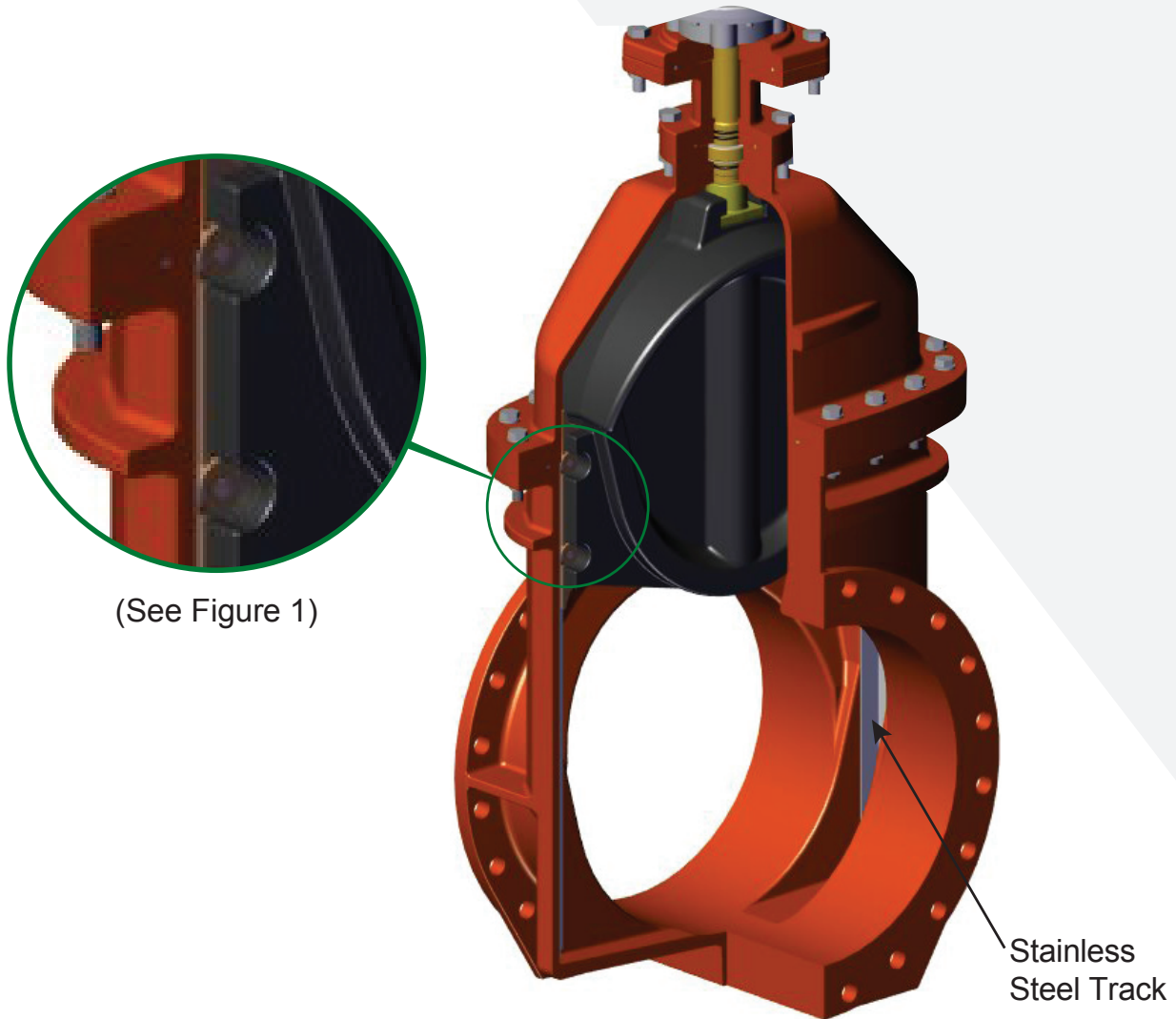
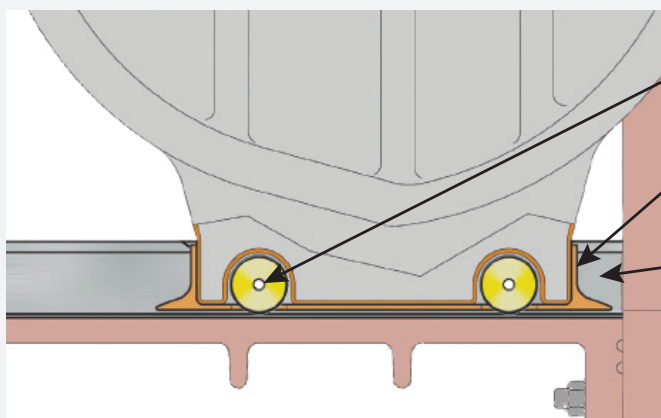

Figure 15

Cleantrack Technology™



Bronze Rollers

Rollers into scraper protect valve body from damage.

Bronze Scraper

Bronze scraper affixed to resilient wedge wing designed for long life performance.

Stainless Steel Track

316 stainless steel track for corrosion and wear resistance.
*Rollers, Tracks & Scrapers (RTS) standard on 24" valves

Figure 16